

FULFLO CARTRIDGE FILTERS

Owners Manual



WARNING

This equipment must be installed and serviced by a qualified technician. Improper installation can create electrical hazards which could result in property damage, serious injury or death. Improper installation will void the warranty.



Notice to Installer

This manual contains important information about the installation, operation and safe use of this product. Once the product has been installed **this manual must be given to the owner/ operator of this equipment.**

IMPORTANT SAFETY INSTRUCTIONS

When installing and using this equipment, basic safety precautions should always be followed, including the following:

READ AND FOLLOW ALL INSTRUCTIONS



WARNING

To reduce the risk of injury, do not permit children to use this product unless they are closely supervised at all times.



WARNING

To reduce the risk of injury, always switch the pump off before attempting to change the position of valves or before attempting to assemble/disassemble any part of the water circulation equipment.



WARNING

Incorrectly installed equipment may fail, causing severe injury or property damage.



WARNING

Do not pressurise beyond the limits stated in the manual. Property damage, serious injury or death may result.



WARNING

Equipment that is incorrectly pressure tested may fail, causing severe injury or property damage. Pressure testing should only be conducted by trained pool/spa professionals.



WARNING

Chemical fumes and spills can weaken pool/spa equipment. Corrosion can cause pumps, filters and other equipment to fail, resulting in severe injury or property damage. Do not store pool chemicals near your equipment.

SAVE THESE INSTRUCTIONS

~ INSTALLATION RECORD ~

Clean Filter Pressure Gauge Reading : _____

.....
Filter Model : _____

Filter Serial : _____

Date of Purchase : _____

Purchased from : _____

.....
Installed by : _____

Installer Phone No : _____

INSTALLATION

1. Check carton and filter components for damage. If anything is damaged, notify the carrier immediately.
2. Wrap one to two turns of Teflon tape around the thread of the pressure gauge. Screw the pressure gauge into the threaded hole on the tank.
3. Filtration equipment should be located as close to the pool/spa as possible. Locate the filter on a flat concrete slab in a well ventilated area free from flooding. Ensure there is adequate drainage.
4. Align the filter so the inlet and outlet are positioned as required. Connect the filter inlet to the pump outlet.
5. Install electrical controls away from pool equipment for access in case of emergency.
6. Allow sufficient clearance around and above the filter to allow for removal of the top section of the tank.
7. To reduce pressure losses, use as few bends, elbows and fittings as possible. Select the appropriate pipe grade as specified by local regulations.
8. Use a minimum of 50mm (2 inch) UPVC piping or larger.
9. Piping should be independently supported to reduce strain on the filter.
10. Do not use tools to tighten the half unions. Hand-tighten only.

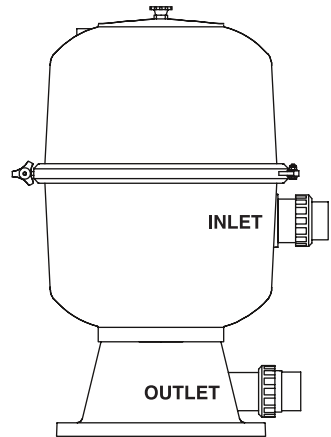

START UP AND OPERATION

Fulflo Cartridge Filter Start Up

The following steps should be carried out for the first run of a new season or after the filter has been reassembled.

1. Ensure the pump is off. Fill the pump's hair and lint pot with water and replace the lid.
2. Loosen (do not remove) the air release valve on the top of the filter.
3. Turn the pump on to circulate water through the system. When a steady amount of water comes out through the top of the air release valve, close the air release valve. All the air will have been purged from inside the filter.

Normal Operation

If the pump loses its prime, you will need to follow the procedure set out for the filter start up. See Section 2.1.

As the dirt load in the filter increases, the pressure gauge reading will rise. When the value has risen 50kPa, you will need to clean the filter. Refer to Maintenance.

MAINTENANCE

Cleaning the Fulflo Cartridge Filter

A general check of the filter and the pressure gauge should be carried out at least once a week.

When the pressure gauge reading has risen by 50kPa it is recommended that the cartridge be cleaned. To do this, follow the procedure below.

1. With the pump off, loosen the air release valve on top of the filter to release pressure from the system.
2. Undo and remove the clamp around the middle of the filter tank by turning the knob anticlockwise.
3. Lift the top portion of the tank up and off the bottom portion, taking care not to damage the cartridge(s) inside.
4. Remove the cartridge(s), caps and spacer and hose down with a garden hose until clean. You may also wish to use a specialised filter cleaning solution to remove debris not flushed away during cleaning. Speak to your local pool professional or contact Waterco.
5. Replace the cartridge(s), caps and spacer.
6. Replace the tank top ensuring the o ring is seated correctly.
7. Replace the clamp and secure by turning the knob clockwise.
8. Follow the steps in Section 2.1 to restart the system.

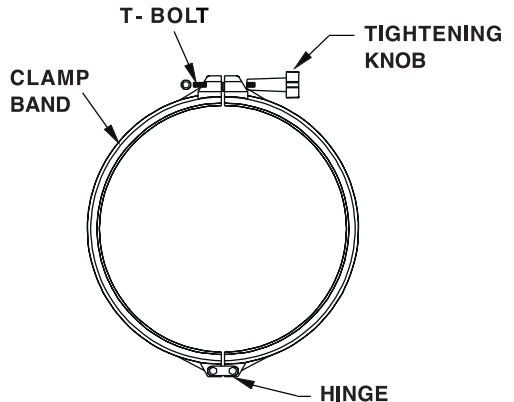

Over time, cleaning the cartridge will become less effective. If you notice the pool water is not looking as clean, or the pressure remains high, it may be beneficial to purchase a new cartridge.

WINTERISING THE FILTER

To protect the filter and connecting piping from damage due to freezing conditions follow the procedure below.

1. Turn off the pump and disconnect from the power supply as per pump instructions.
2. Loosen the air release valve on top of the filter to release pressure from the system.
3. Undo the half union at the base of the filter to drain the water from the filter.
4. Drain the piping of all water.
5. Protect the filter from the weather.

TROUBLE SHOOTING

The list below contains the more common problems that can occur with this equipment. If you cannot identify the fault from the list below, consult Waterco or your local pool professional.

SYMPTOMS	CAUSE	POSSIBLE SOLUTION
WATER IS NOT CLEAR	Incorrect pool chemistry	Check with your local pool professional.
	Insufficient disinfectant levels	Check with your local pool professional.
	Heavy bathing or dirt loads	Increase disinfectant levels and running time.
	Flow rate too high. Contaminants passing through filter.	Reduce flow rate.
	Insufficient running time	Increase running time.
	Filter is dirty	Clean or replace cartridge.
	Damaged cartridge	Replace cartridge.
DIRT RETURNS TO POOL	Flow rate too high. Contaminants passing through filter.	Reduce flow rate.
	Damaged cartridge	Replace cartridge.
	Water by-passing cartridge	Check for damaged seals or missing spacers in the filter.
LOW WATER FLOW	Clogged strainer basket eg in pump or skimmer box	Remove debris.
	Partly opened valve	Fully open valves.
	Air leak in suction side of pump	Check pump and valve seals, tighten unions.
	Filter is dirty	Clean or replace cartridge.
	Faulty pump	Refer to Troubleshooting section of the pump manual.
UNUSUALLY HIGH PRESSURE	Blockage in return line	Open valves, clear any blockages.
	Filter is dirty	Clean or replace cartridge.
FREQUENT CLEANING REQUIRED	Insufficient disinfectant levels	Check with your local pool professional.
	High nutrient levels in the pool favourable to algae growth	Check with your local pool professional.
	Check condition of cartridge	Clean or replace cartridge.

TECHNICAL SPECIFICATIONS

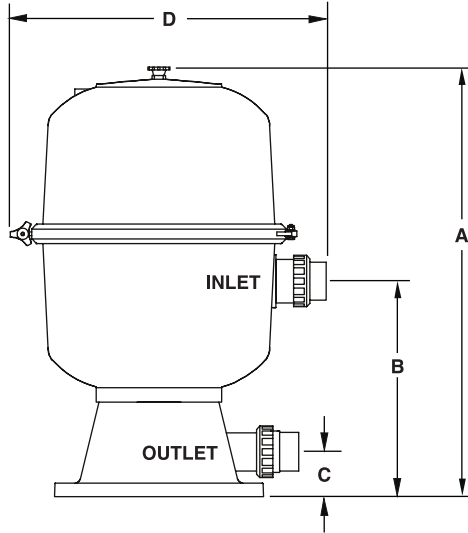

Model	A	B	C	D
P200	850mm	615mm	95mm	500mm
P300	1050mm	615mm	95mm	500mm
P400	1250mm	615mm	95mm	500mm
TC300	1250mm	615mm	95mm	500mm
TC400	1250mm	615mm	95mm	500mm
TC500	1250mm	615mm	95mm	500mm

Model	Filter Area sq ft (m ²)	Max flow rate lpm	Max Pool Size litres	Max Working Pressure kPa
P200	200 (18.58)	284	102,240	350
P300	300 (27.87)	424	152,640	350
P400	400 (37.16)	568	204,480	350
TC300	300 (28.87)	424	152,640	350
TC400	400 (37.16)	568	204,480	350
TC500	500 (46.4)	650	230,000	350

OFFICES - AUSTRALIA

NSW - SYDNEY
(HEAD OFFICE)
Tel: +61 2 9898 8600

QLD - BRISBANE
Tel: +61 7 3299 9900

VIC/TAS - MELBOURNE
Tel: +61 3 9764 1211

WA - PERTH
Tel: +61 8 9273 1900

SA/NT - ADELAIDE
Tel: +61 8 8244 6000

ACT DISTRIBUTION
Tel: +61 2 6280 6476

OFFICES - OVERSEAS

WATERCO (EUROPE) LIMITED
Sittingbourne, Kent, UK
Tel: +44 (0) 1795 521 733

WATERCO FRANCE
Saint Priest, France
Tel: +33 4 72 79 33 30

WATERCO (USA) INC
Augusta, Georgia, USA
Tel: +1 706 793 7291

WATERCO CANADA
Longueuil, Quebec, Canada
Tel: +1 450 748 1421

WATERCO (NZ) LIMITED
Auckland, New Zealand
Tel: +64 9 525 7570

WATERCO © LIMITED
Guangzhou, China
Tel: +86 20 3222 2180

WATERCO (FAR EAST) SDN BHD
Selangor, Malaysia
Tel: +60 3 6145 6000

PT WATERCO INDONESIA
Jakarta, Indonesia
Tel: +62 21 4585 1481

WATERCO SINGAPORE INTL PTE LTD
Nehsons Building, Singapore
Tel: +65 6344 2378